

Item ref.: 22-243/T Extended Code: 22-243

Item description: FS SUNDAE SPOON LONG 18 CM TRANS 8X250 Colour: Assorted

Material: PS Technology: Injection molding

EAN code: 7394379880336 Customizable

Restriction in use: Not microwaveable

PRODUCT SPECIFICATIONS

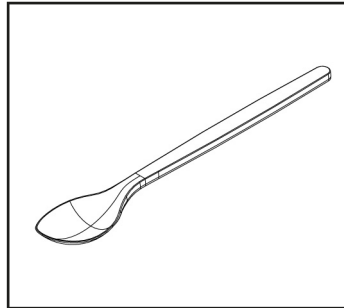
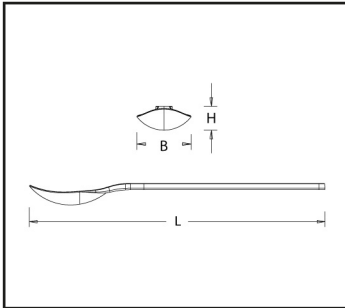

U.M.= mm

Net weight (gr): 3,00 Total capacity (cc): _____

Length (L): 180,00 Width (B): 30,00 Height (H): _____

Int. Diameter (d1): _____ Ext. Diameter (d2): _____

Note: _____

PACKAGING SPECIFICATIONS

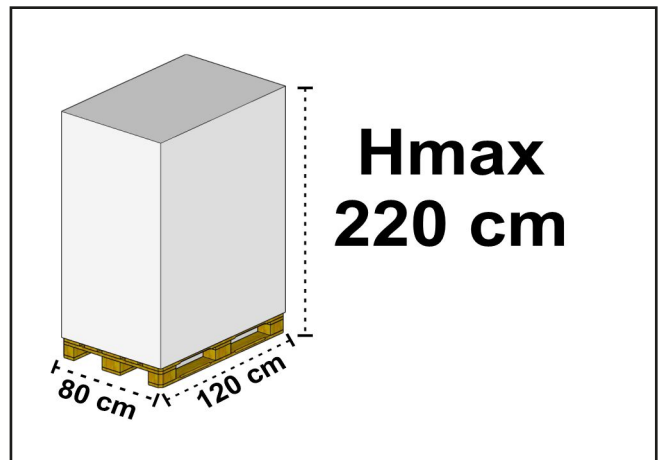
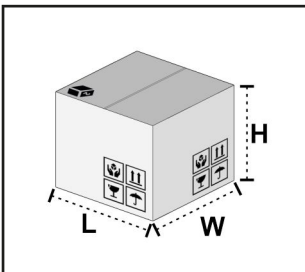

U.M.= cm

Nr of pcs per box 2000

Nr of pcs per inner packaging: 250

Nr of inner packaging per box: 8

Box measures: Length: 39,00 Width: 59,00 Height: 34,00

Box gross weight (Kg): 7,10 Nr of boxes per pallet: 24

